

Passenger 4

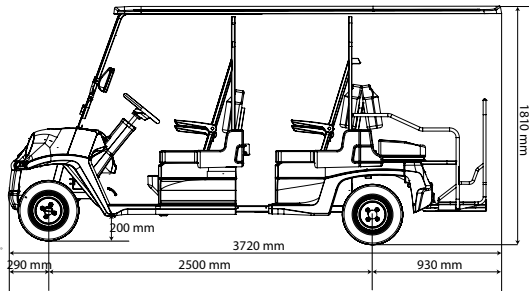

Passenger 6

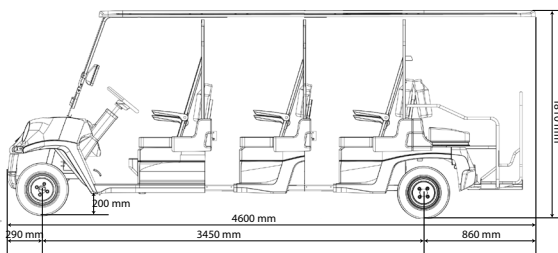

Passenger 8

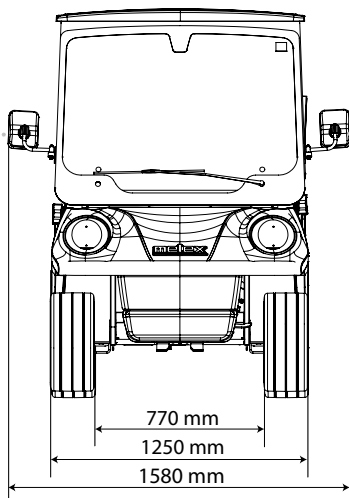

	PASSENGER 4	PASSENGER 6	PASSENGER 8
MOTOR	48V 3-phase AC	48V 3-phase AC	48V 3-phase AC
NOMINAL POWER	3,3 kW / 5.0 kW	5,0 kW	5,0 kW
PEAK POWER	9 kW / 11,5 kW	11,5 kW	11,5 kW
MAX TORQUE	40 Nm / 75 Nm	75 Nm	75 Nm
MOTOR CONTROLLER	350A	350A	350A
CHASSIS	Hot dip galvanized steel frame	Hot dip galvanized steel frame	Hot dip galvanized steel frame
BRAKES	Hydraulic brakes - drum (F) & drum (R)	Hydraulic brakes - drum (F) & drum (R)	Hydraulic brakes - drum (F) & drum (R)
SUSPENSIONS	Double wishbone (F) - Leaf spring (R)	Double wishbone (F) - Leaf spring (R)	Double wishbone (F) - Leaf spring (R)
TIRES	195/55-10	195/55-10	20,5/x8.0-10
TOW LOAD CAPACITY	250kg	250kg	N/A

PERFORMANCE

TOP SPEED	33 km/h
------------------	---------

MASS

VEHICLE WEIGHT (without battery and options)	385kg	575kg	690kg
--	-------	-------	-------

DIMENSIONS

LENGTH	2900 mm	3720 mm	4600 mm
WIDTH (without / with mirrors)	1250 mm / 1580 mm	1250 mm / 1580 mm	1250 mm / 1580 mm
HEIGHT	1810 mm	1810 mm	1810 mm
WHEELBASE	1660 mm	2500 mm	3450 mm
OUTER TURNING RADIUS	3350 mm	4600 mm	6250 mm

STANDARD FEATURES

P4: 3,3 kW AC motor, 48V on-board battery charger, LED front & rear lights, 12V output, 10" wheels, windshield with wipers, hydraulic drum brakes, 3-point seat belts

P6, P8: 5,0 kW AC motor, 48V on-board battery charger, LED front & rear lights, 12V output, 10" wheels, windshield with wipers, hydraulic drum brakes, 3-point seat belts

OPTIONAL FEATURES

P4: 5,0 kW drive motor, water filling system for Flood Lead Acid (FLA) batteries, heated front windshield, FM or DAB radio with Bluetooth, profiled seats, foldable rear seat, mesh cage, reverse camera, closed glove compartment, forward drive warning sound, beacons, bumper

P6, P8: Water filling system for Flood Lead Acid (FLA) batteries, mesh cage, tow hook, heated front windshield, FM or DAB radio with Bluetooth, profiled seats, foldable rear seat, reverse camera, closed glove compartment, forward drive warning sound, beacons, bumper

BATTERY	P4, P6, P8 FLA		P4, P6, P8 LI-ION		
CAPACITY	T125 240Ah std.	T145 260Ah	6,2 kWh	9,3 kWh	12,4 kWh
VOLTAGE	48 V	48 V	48 V	48 V	48 V
WEIGHT	240 kg	270 kg	38 kg	57 kg	76 kg
CHARGE TIME	~11 h	~11 h	~4,5 h	~6,5 h	~9,5 h