

### N.20 CARGO SHORT

\*with pickup bed 770 x 1170 x 250 mm

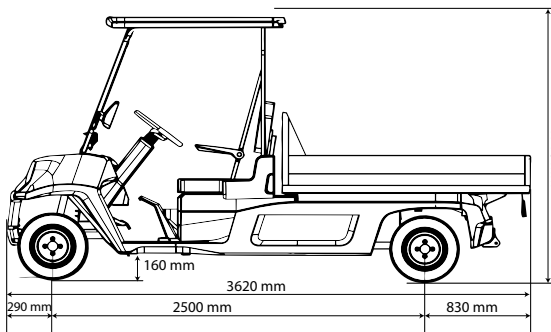
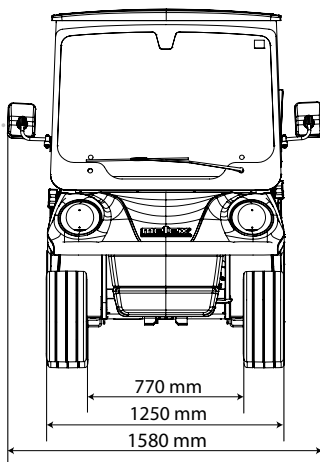

### N.20 CARGO LONG

\*with pickup bed 1770 x 1200 x 250 mm

	CARGO SHORT	CARGO LONG
<b>MOTOR</b>	48V 3-phase AC	48V 3-phase AC
<b>NOMINAL POWER</b>	3,3 kW / 5,0 kW	5,0 kW
<b>PEAK POWER</b>	9 kW / 11,5 kW	11,5 kW
<b>MAX TORQUE</b>	40 Nm / 75 Nm	75 Nm
<b>MOTOR CONTROLLER</b>	350A	350A
<b>CHASSIS</b>	Hot dip galvanized steel frame	Hot dip galvanized steel frame
<b>BRAKES</b>	Hydraulic drum brakes	Hydraulic drum brakes
<b>SUSPENSIONS</b>	Double wishbone (F) - Leaf spring(R)	Double wishbone (F) - Leaf spring(R)
<b>TIRES</b>	195/55 R10	195/55 R10
<b>TOW LOAD CAPACITY</b>	220 kg	260 kg

### PERFORMANCE

<b>TOP SPEED</b>	33 km/h
------------------	---------

### MASS

<b>CHASSIS PAYLOAD</b>	up to 200 kg	up to 515 kg
<b>VEHICLE WEIGHT</b> (without battery and options)	480 kg	540 kg

### DIMENSIONS

<b>LENGTH*</b>	2600 mm	3620 mm
<b>WIDTH</b> (without / with mirrors)	1250 mm / 1580 mm	1250 mm / 1580 mm
<b>HEIGHT</b>	1710 mm	1710 mm
<b>WHEELBASE</b>	1630 mm	2500 mm
<b>OUTER TURNING RADIUS</b>	3300 mm	4600 mm

### PICKUP BED OPTIONS length x width x height - material

<b>770 x 1145 x 250 mm</b> - profiled alu	<b>1770 x 1200 x 250 mm</b> - alu plate
<b>950 x 1170 x 250 mm</b> - profiled alu	<b>1750 x 1240 x 250 mm</b> - profiled alu
<b>950 x 1170 x 350 mm</b> - profiled alu	<b>1750 x 1240 x 350 mm</b> - profiled alu

### STANDARD FEATURES

3,3 kW AC motor Cargo Short, 5,0 kW AC motor Cargo Long, 48V on-board battery charger, LED front & rear lights, 12V output, 10" wheels, windshield with wipers, hydraulic drum brakes, 3-point seat belts

### OPTIONAL FEATURES

5,0 kW drive motor (Cargo Short), water filling system for Flood Lead Acid (FLA) batteries, heated front windshield, tilt system (Cargo Long), mesh cages, frame structure with a canvas cover, tow hook, FM or DAB radio with Bluetooth, profiled seats, closed glove compartment, reverse camera, forward drive warning sound, beacons, roof bars, bumper

BATTERY	SHORT & LONG FLA		SHORT & LONG LI-ION		
<b>CAPACITY</b>	T125 240Ah	T145 260Ah	6,2 kWh	9,3 kWh	12,4 kWh
<b>VOLTAGE</b>	48 V	48 V	48 V	48 V	48 V
<b>WEIGHT</b>	240 kg	270 kg	38 kg	57 kg	76 kg
<b>CHARGE TIME</b>	~11 h	~11 h	~4,5 h	~6,5 h	~9,5 h